

The Marine Galvanic Isolator (GI)



INTRODUCTION

The DEI Galvanic Isolator (GI) is a fail-safe class, solid-state DC isolation/ AC coupling device with ratings and characteristics that significantly exceed those of all known galvanic isolators designed for marine applications. Whenever a boat is connected to AC shore power, a galvanic circuit, which can cause corrosion of the boat and its drive system components, is established. Due to the difference in the potential of the hull and drive system metals compared with the shore grounding system or other boats, a galvanic current, which causes corrosion, can flow. A galvanic isolator is installed in series with the shore power cable grounding conductor to prevent the flow of galvanic current. If the galvanic isolator is a fail-safe class product, then the galvanic isolator will never compromise the integrity of the shore grounding conductor. A typical installation schematic is shown in Figure 5.

Fail-Safe Criteria

In the marine industry, the criteria for galvanic isolators is defined by the American Boat and Yacht Council (ABYC) recommended standard A-28. Due to recommendations to the A-28 galvanic isolator committee about the need to retain safety grounding under all conditions, as required by the U.S. National Electrical Code for all similar applications outside of A-28, this standard has been revised with a publication date of July 2008 and an effective date of July 2009. To be considered "fail-safe," an independent laboratory must confirm that the isolator will either remain fully functional or remain a permanent, effective grounding path if it fails, when subject to the ultimate current-carrying capability of the grounding conductor (i.e. the energy required to melt the conductor). In contrast, isolators on the market not deemed "fail-safe" to the A-28 criteria are not required to maintain a permanent ground return path, and therefore may fail as an open circuit - a

potentially dangerous and unacceptable condition - hence, the reason such isolators require monitoring systems, per ABYC. Without assured grounding, the boat can rise to unsafe voltage levels during fault or lightning conditions, or prevent safety grounding of failing electrical devices on the boat or if the boat is miswired. The fail-safe criteria in the revised A-28 standard relates the isolator current/time ratings to the associated grounding conductor size and capability, assuring that the isolator would never compromise the integrity of the safety grounding conductor. This important safety feature eliminates the need for a monitoring system, which will not be required for any isolator deemed "fail-safe."

**Galvanic Isolator For
30A Services**



**Galvanic Isolator For
50/60A Services**



**Galvanic Isolator For
100 Amp Services**



DEI PRODUCT OVERVIEW

DEI manufactures fail-safe Galvanic Isolators which have been tested and certified to ABYC A-28, July 2008 publication, by Imanna Laboratory, Inc. DEI's extensive experience with solid-state grounding devices and "decouplers" dates back to 1983, manufacturing conservatively designed products for high power applications in the power utility, pipeline, and railroad markets. DEI manufactures isolators for other industries that have identical construction to the Galvanic Isolator line, and which have been fully tested and listed by Underwriters Laboratories to US and Canadian electrical codes (NEC, CSA, etc) for safety grounding and suitability for hazardous locations. The units were further tested by UL/Demko to meet European requirements. These electrical codes are much more demanding than the ABYC A-28 standard, where fail-safe construction is not optional, but required. Those products, identical to the Galvanic Isolator line, are routinely inspected by UL for compliance. No other isolator design has been subjected to such extensive testing and certification. All DEI Galvanic Isolators are considered "Fail-Safe Plus" or "Fail-Safe MAX," defined in the following sections.

DEI offers Galvanic Isolators rated 30A, 50/60A, 100A, and 200A. The scope of A-28 covers ratings through 100A, but the 200A model has similar construction to the certified models, with a full 200A continuous current rating (plus overload margin per ABYC).

Fail-Safe Plus™

Fail-Safe Plus models not only meet the fail-safe test criteria in A-28, but also have considerably higher AC fault current ratings than are required and have substantial lightning current ratings which are not required by A-28; hence, the "Plus" version unique to DEI.

Fail-Safe Max™

Fail-Safe Max models provide even higher performance than Fail-Safe Plus models, in that they have higher fault current ratings and will still be fully functional and meet all requirements of A-28 after being subject to the fail-safe test criteria (i.e. the energy required to melt the conductor).

Unique Features

DEI offers a unique combination of product features and ratings. These include:

- Highest AC fault current ratings
- Rated for lightning current. No other known galvanic isolators have published lightning current ratings
- Ignition protected
- Verified Fail-safe construction
- Optional "Fail-Safe Max" ratings
- Longest warranties offered in the industry
- Certified to ABYC A-28 as "Fail-Safe"
- No monitoring system required per ABYC A-28
- Compact design
- Designed for cool operation - no heat sinks needed
- Prevents the flow of galvanic current with super imposed AC current well above the 3A minimum required by A-28
- Designed to meet stringent NEC land-based grounding requirements (exceeds marine requirements)

Product Capabilities

The key parameters of the DEI Galvanic Isolator are:

- Blocking voltage
- DC leakage current for a given blocking voltage
- Steady-state AC current rating
- AC fault current rating
- Lightning surge current rating

Blocking Voltage

Per ABYC A-28, the DEI model GI family has a DC blocking voltage of at least 1V. At a voltage below this value, the GI blocks the flow of DC

current and allows AC current to pass. At voltages above the blocking voltage, such as could occur from an AC fault or lightning, the GI is a bi-directional conduction device that readily allows all current to flow, thereby safely limiting the voltage on the boat.

System Voltage

DEI Galvanic Isolators are strictly current rated and can be used on any voltage class system. Since A-28 requires a system voltage rating on the nameplate, all DEI Galvanic Isolators are nameplated for use on systems of 600Vac or less.

DC Leakage Current

For a given DC voltage across the GI, there will be a small DC leakage current. This value will be negligible (less than 1mA) at the worst case galvanic voltage difference anticipated across the device, and well below the limits in ABYC A-28. The leakage current is a corrosion-causing current that is minimized with the DEI design.

Steady-State AC Current

Galvanic isolator models are rated to carry the steady state AC current for which the shore power cable is rated. The ratings offered by DEI are 30A (which has been certified and nameplated for 35A continuous to satisfy European requirements for a 32A rating), 50/60A (for a single 50A shore cord or two 30A shore cords), 100A (for a single 100A shore cord or two 50A shore cords), and 200A (for a single 200A shore cord or two 100A shore cords). Where dual shore cords of the same rating are used on a boat, the most economical choices are: For two 30A shore cords on a boat, use one 50/60A model and for two 50A shore cords on a boat, use two 50/60A models.

Exceptions:

If the shore power steady-state current rating is different from the above values, choose a GI rating that exceeds the shore power rating. When in doubt about ratings, contact DEI.

AC Fault Current

All DEI Galvanic Isolators are designed to exceed the ABYC A-28 ratings for AC fault current. When a boat is connected to shore power, if a fault on the boat occurs, the isolator will be exposed to fault current until the appropriate breaker operates. DEI offers models that have assured fail-safe operation, based on testing to the equivalent failure level of the shore power cable grounding conductor required for a given current rating. The standard conductor sizes used for testing were: #8 AWG for 30A models, #6 AWG for 50/60A models, and #2 AWG for 100A models. An even higher level of performance and protection is offered in the “Fail-Safe Max” line, with units that remain fully functional after being exposed to the fail-safe isolator test criteria in A-28. Following are the fault ratings of all DEI models, in amperes rms symmetrical, for both the Fail-Safe Plus and Fail-Safe Max classes. For comparison, per the A-28 standard, non-fail-safe galvanic isolators are only required to be tested for one cycle at the fault current ratings shown below, for three consecutive times. DEI products greatly exceed any minimum requirements.

AC Fault Current Ratings (Amps AC-RMS Symmetrical)

Model	Fault Rating	Product Class
GI-30A-FSP*	3kA for 13 cycles	Fail-Safe Plus
GI-30A-FSM	3kA for 34 cycles	Fail-Safe Max
GI-50/60A-FSP	5kA for 10 cycles	Fail-Safe Plus
GI-50/60A-FSM	5kA for 31 cycles	Fail-Safe Max
GI-100A-FSM	5kA for 198 cycles	Fail-Safe Max
GI-200A-FSM	5kA for 198 cycles	Fail-Safe Max

* The model GI-30A-FSP is Fail-Safe Plus when used with a #8 AWG grounding conductor, and is effectively a Fail-Safe Max product when used with a #10 conductor.

Lightning Surge Current

Although not a requirement of A-28, DEI has established substantial lightning current ratings for all Galvanic Isolators, as this is a common practice for similar products used in other industries. The lightning surge current rating should not be confused with the AC fault current rating. Lightning has a very different waveform, with a faster rise time, a shorter duration, and much less energy than for an AC current waveform of the same peak current. However, lightning develops much larger voltage differences along the current flow path than AC, resulting in arcing, equipment damage, or personnel risks. Lightning current ratings for DEI Galvanic Isolators were established by subjecting the galvanic isolator to representative lightning current in a high power test laboratory per the requirements of ANSI C62.11. The waveform used for DEI testing is described as an industry standard 4x10 μ s waveform. This describes a lightning waveform where the rise time is 4 microseconds to peak value, followed by decay to one-half of peak in 10 microseconds. The following models have the peak current rating stated.

Lightning Surge Current Rating

Model	Lightning Current	Product Class
GI-30A-FSP	75kA peak	Fail-Safe Plus
GI-30A-FSM	100kA peak	Fail-Safe Max
GI-50/60A-FSP	100kA peak	Fail-Safe Plus
GI-50/60A-FSM	100kA peak	Fail-Safe Max
GI-100A-FSM	100kA peak	Fail-Safe Max
GI-200A-FSM	100kA peak	Fail-Safe Max

FEATURES AND CHARACTERISTICS

Certification

The DEI line of Galvanic Isolators was tested and certified by Imanna Laboratory, Inc of Rockledge, FL to the ABYC A-28 standard, July 2008 publication. As defined in the standard, all DEI products are “Ignition Protected” and “Fail-Safe,” or beyond the requirements of fail-safe as previously described (i.e., Fail-Safe Plus and Fail-Safe Max).

* Note: While ABYC A-28 standards do not specify requirements for a 200A device, DEI's 200A Galvanic Isolator was tested to the criteria that would apply if the requirements of A-28 were extended to this rating.

Solid-State Design

The DEI Galvanic Isolator utilizes solid-state components in proven designs supplied to the energy industries since 1983. The design has an instantaneous response to voltage, initiating voltage clamping immediately when the voltage attempts to exceed the blocking level. The design includes a non-polarized capacitor. All DEI products are fail-safe by design.

Warranty

Due to the conservative design, DEI offers significantly longer warranties than other products on the market. The warranty for a Fail-Safe Plus class product is 2 years, and for a Fail-Safe Max class product is 4 years. During the warranty period, any model will be repaired or replaced due to failure for any cause.

Field Testing/Maintenance

The Galvanic Isolator can be field tested with a multi-meter and clamp on DC ammeter. Testing procedures are included in the installation instructions. The Galvanic Isolator is completely maintenance-free.

Enclosure

The 30A and 50/60A models are packaged in a molded, non-metallic enclosure rated IP68. See Figure 1 and 2. The 100A and 200A models are

packaged in a molded, non-metallic fiberglass enclosure rated NEMA 4X. See Figures 3 and 4.

Polarity/Electrical Connection

The Galvanic Isolator terminals do not include polarity marks because it is bi-directional and symmetrical in design. However, the terminals are marked as "Boat Ground" and "Shore Ground" to avoid confusion or inadvertent bypassing of the device. Conductors are to be terminated with one-hole cable lead connectors (user furnished) by bolting, using the hardware supplied by DEI. The connector should be sized for a 5/16" diameter bolt for 30A and 50/60A models, and for a 1/2" diameter bolt for the 100A and 200A models. Torque values are included in the installation instructions.

Number of Operations

The number of times that the Galvanic Isolator can be subject to its rated lightning or AC fault current rating is virtually unlimited, provided the operations are not immediately repetitive.

Energy Requirements

None. The device is completely passive.

Ambient Operating Temperature

-45°C to +65°C

Monitoring

The DEI Fail-Safe Plus and Fail-Safe Max line of Galvanic Isolators are not provided with a monitor because in the next proposed revision to A-28 standard (July 2008 publication), monitoring has been eliminated as a requirement for galvanic isolators classified as Fail-Safe per A-28. Monitoring will still be required for isolators made by others that are not certified as fail-safe.

Figure 1 Galvanic Isolator Outline Drawing for 30A Models

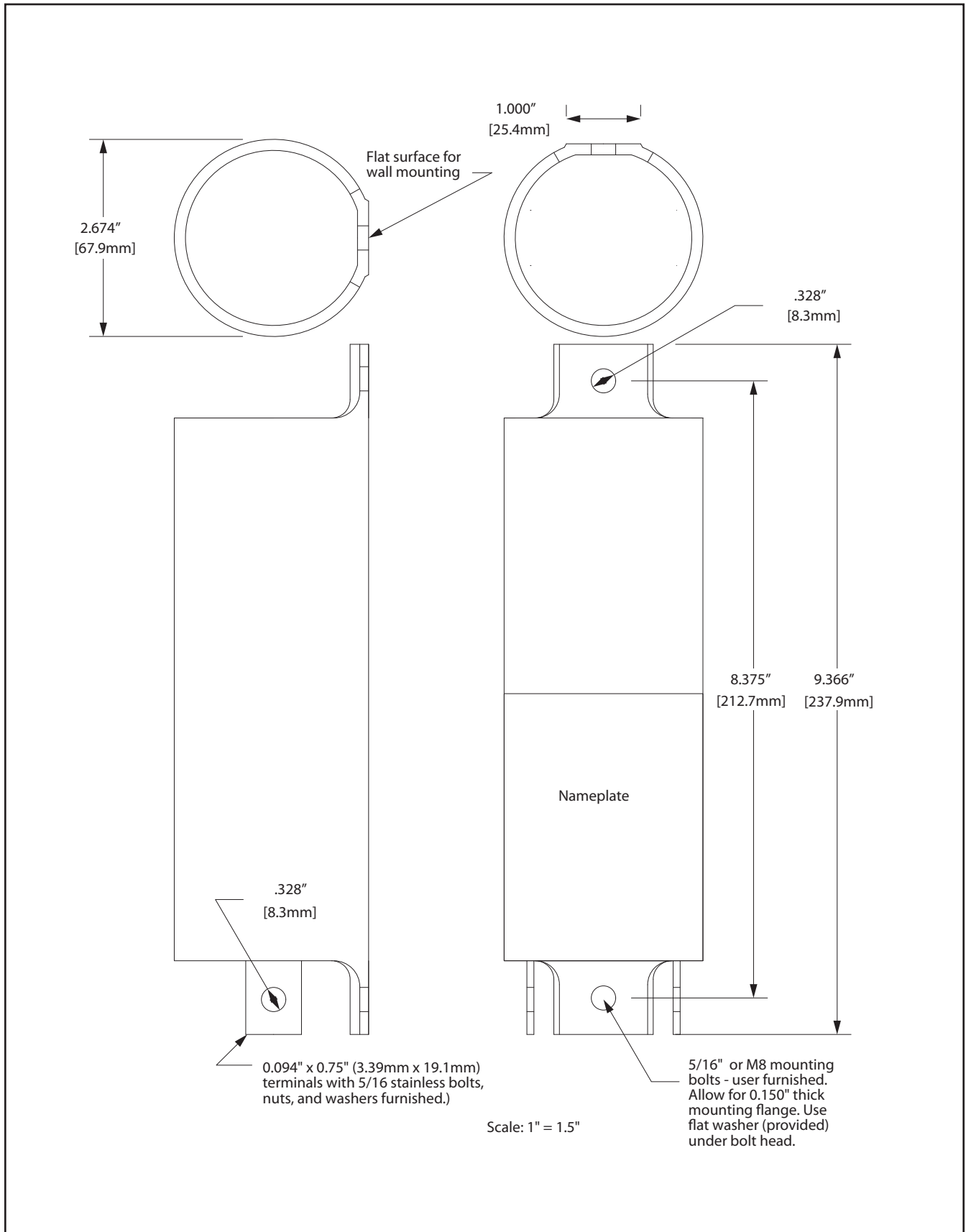

Figure 2 Galvanic Isolator Outline Drawing for 50/60A Models

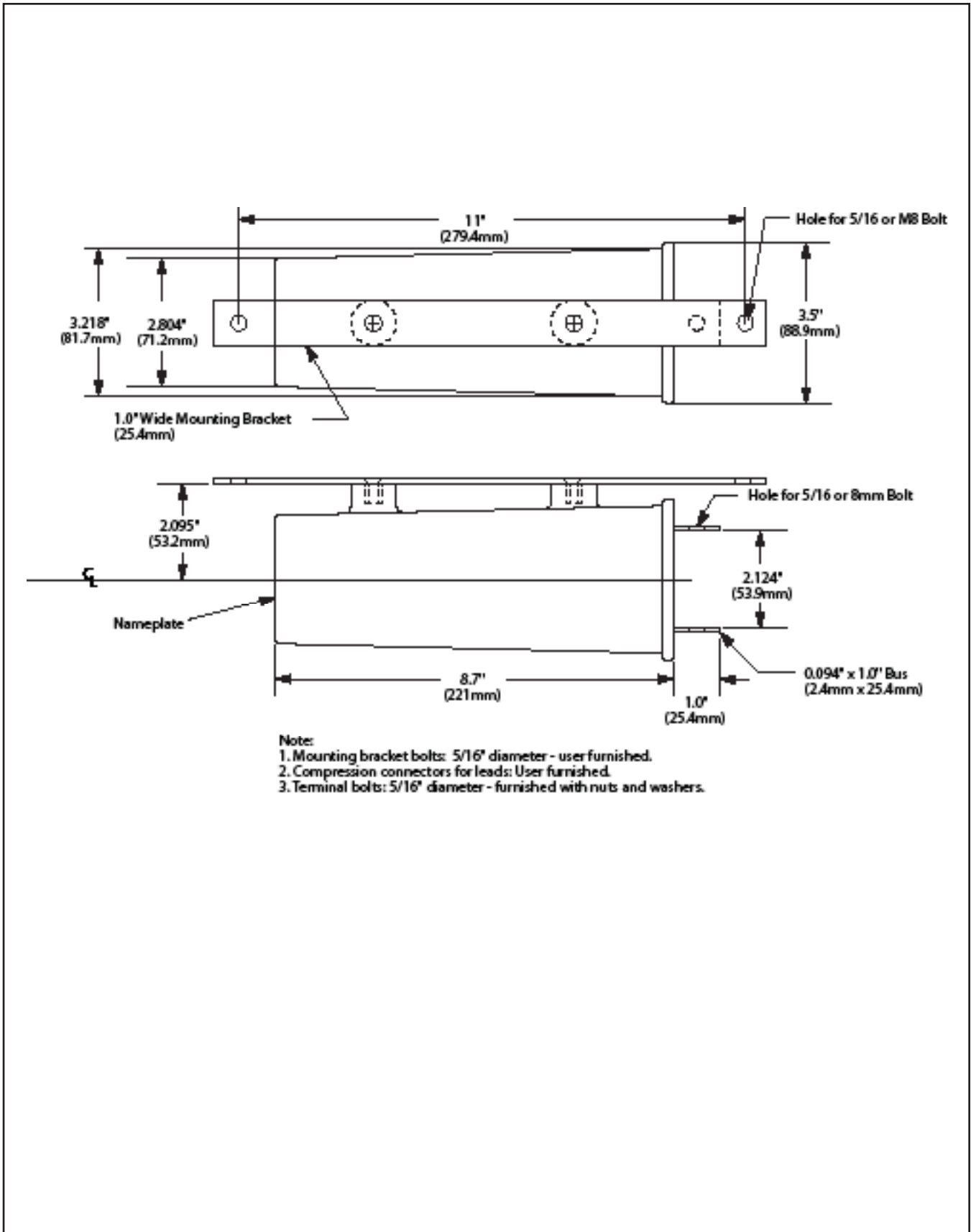
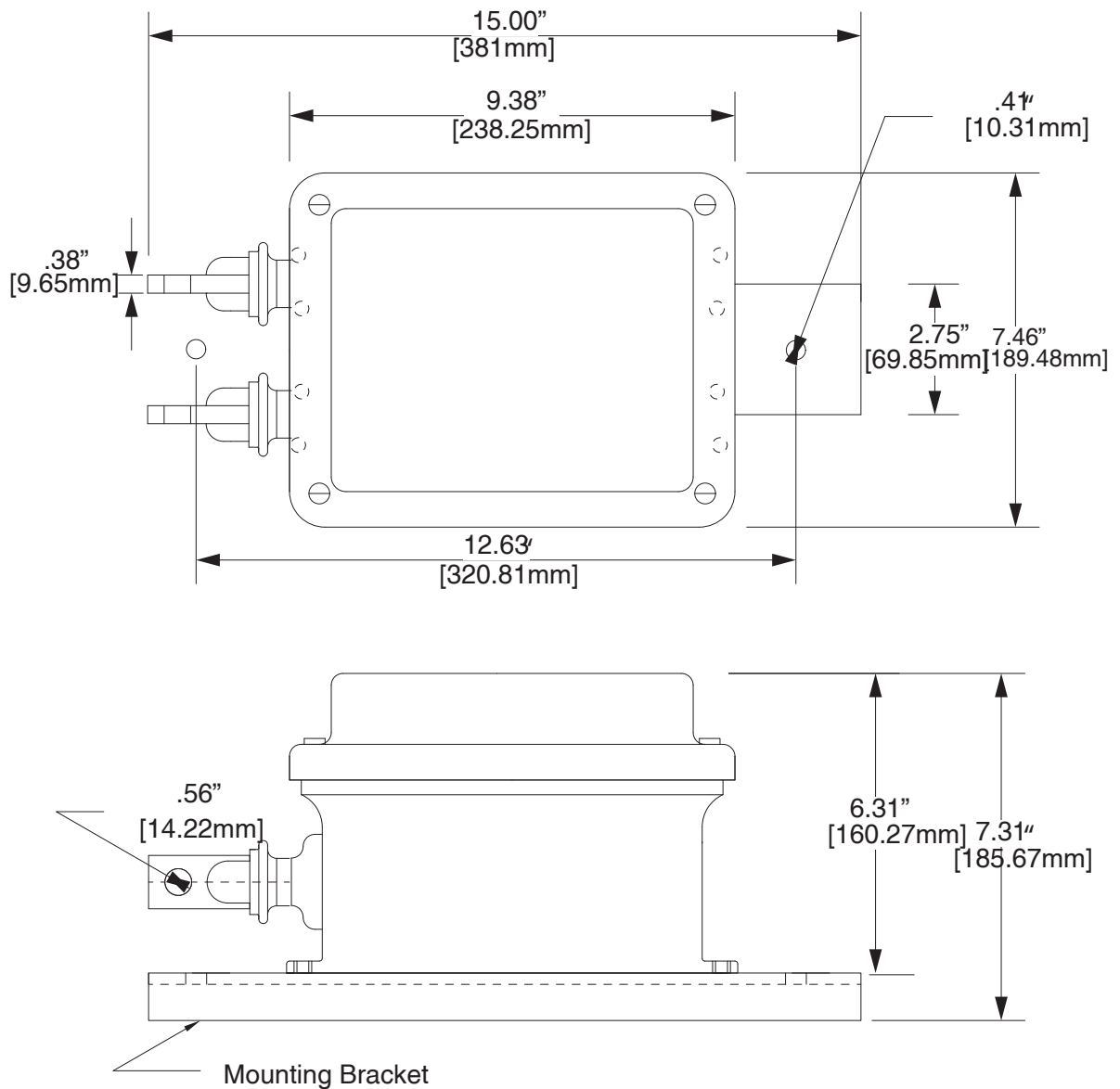

Figure 3 Galvanic Isolator Outline Drawing for 100A Model



Note:

1. If desired, the mounting bracket furnished can be removed and the galvanic isolator can be mounted using the flanges on the enclosure. Four inner mounting holes are located on 1.75" x 8.75" centers and four outer mounting holes are located on 4" x 8.88" centers.
2. Mounting with the bracket provided requires (2) 3/8" (10mm) bolts and mounting by using the enclosure flange requires (4) 1/4" (6mm) bolts - user furnished.
3. Terminal bolts (1/2" diameter) are furnished with nuts and washers, not shown.
4. Compression connectors for leads - user furnished.
5. Dimensions in inches and millimeters.

Figure 4 Galvanic Isolator Outline Drawing for 200A Model

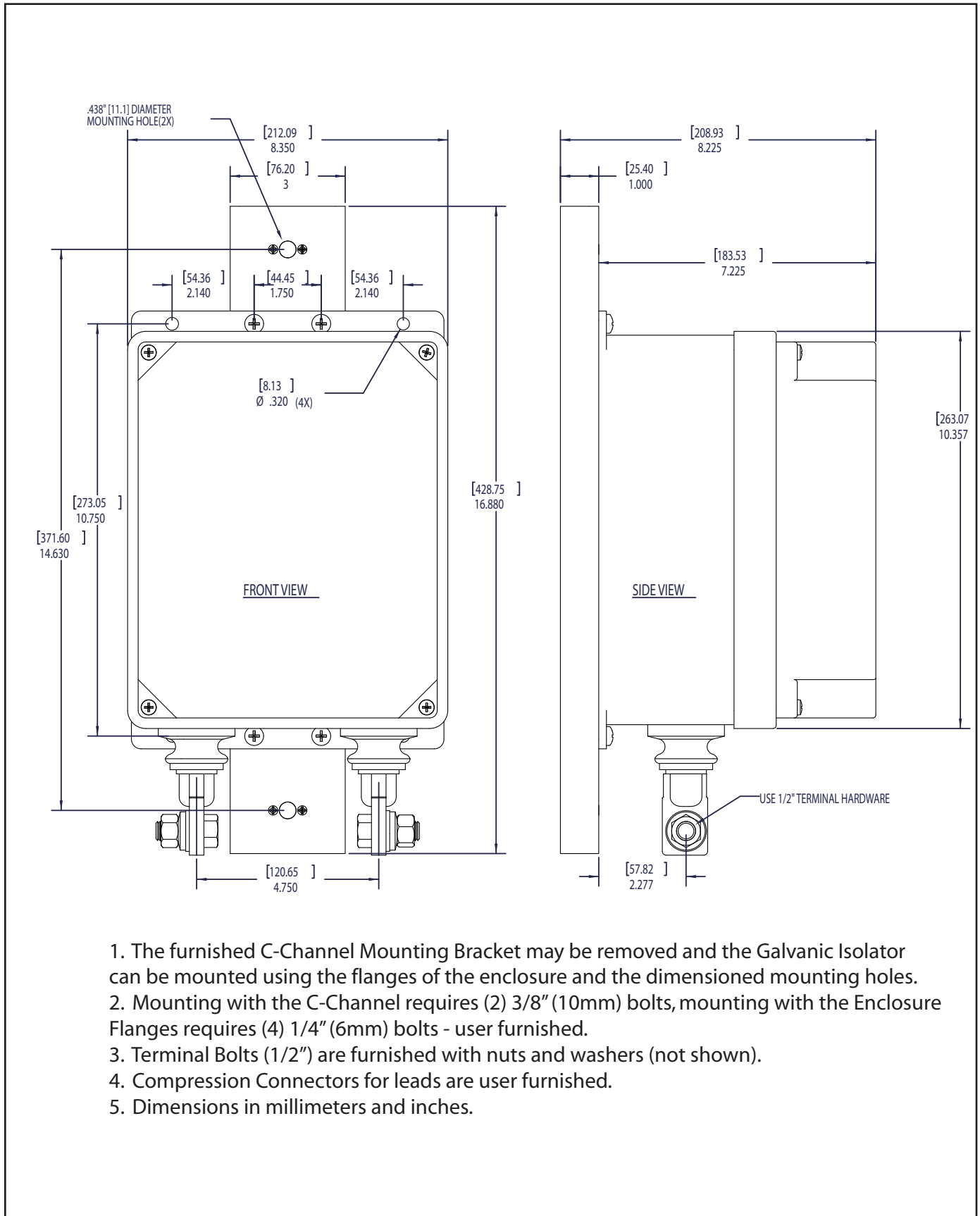

1. The furnished C-Channel Mounting Bracket may be removed and the Galvanic Isolator can be mounted using the flanges of the enclosure and the dimensioned mounting holes.
2. Mounting with the C-Channel requires (2) 3/8" (10mm) bolts, mounting with the Enclosure Flanges requires (4) 1/4" (6mm) bolts - user furnished.
3. Terminal Bolts (1/2") are furnished with nuts and washers (not shown).
4. Compression Connectors for leads are user furnished.
5. Dimensions in millimeters and inches.

FIGURE 4 Typical Installation of a Galvanic Isolator for Marine Vessel Application

